

**AF - □□□ - 1 2 - □**

Add 7/8" for Magnetic Piston

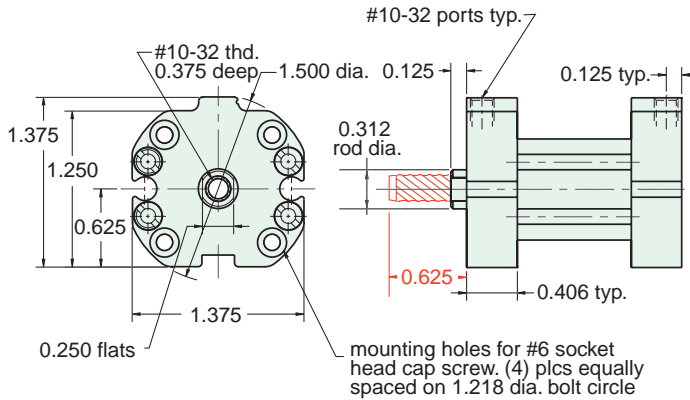

For rod with male thread option, add -T to the end of the part number after Stroke

See page 76 for Air Force One numbering system

## MOUNTING STYLES

Five mounting styles give you versatility and fast, easy installation.

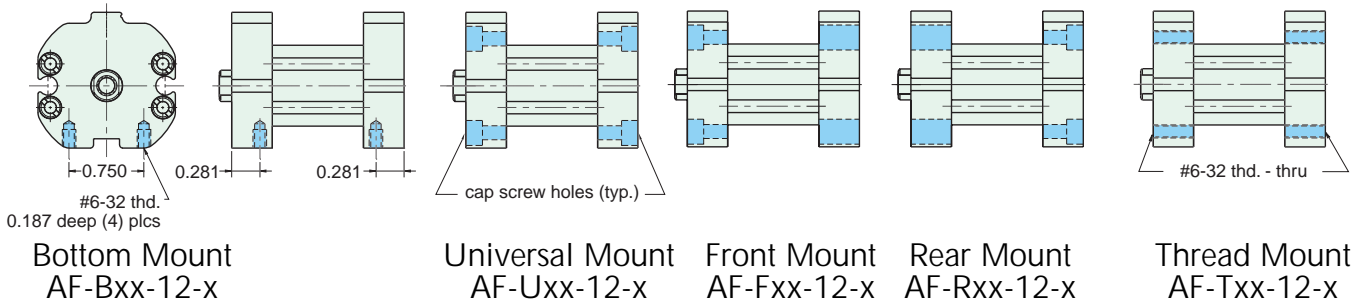

## CYLINDER LENGTHS

"L"	Stroke	Spring Return	Spring Extend
L1	1/4" - 1"	13/16"	
L1	1 1/8" - 2"	1 3/8"	
L1	2 1/8" - 3"	1 15/16"	
L1	3 1/8" - 4"	2 1/2"	
L2	1/4" - 1"		1 1/16"
L2	1 1/8" - 2"		1 5/8"
L2	2 1/8" - 3"		2 3/16"
L2	3 1/8" - 4"		2 3/4"

Overall length of body is stroke plus "L"

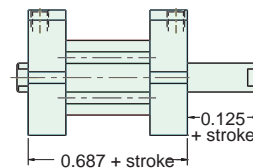
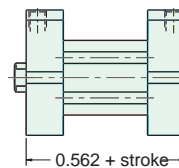
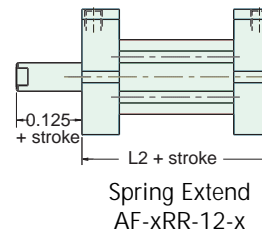
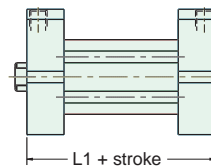

Spring Forces	
Spring Return	
Compressed	At Rest
10 lbs.	4 lbs.
Spring Extend	
Compressed	At Rest
10 lbs.	4 lbs.